

PIVOTING PALLET FILLING EQUIPMENT ELEMENTRA[®] 26



ELEMENTRA® 26, mobile

Thanks to extensive peripherals, the ELEMENTRA® 26 meets the special requirements of the filling products and the respective environment. New features provide for even more accuracy and sustainability.

The new touch panel including the FEIGE web HMI offers an intuitive design for high operating comfort. This FEIGE equipment version is particularly efficient, **POWER** with pneumatically driven components being designed electrically, thus saving cost-intensive compressed air.

FEIGE **POWER**
= Electric lifting unit

● Base height adjustment

- With continuously adjustable base height adjustment for changing over to different container heights

● Electric lifting unit

- Servodrive **POWER**
- Saving expensive energy (compressed air)
- Exhaust-free use also in clean rooms
- With-surface filling possible

● Electric Actuator for opening and closing the filling valve

- 2-stage push-type for coarse fill and adjustable fine fill
- Stainless steel quick-change holder of filling valve for quick replacement of the valve with lance

● Fill level and status indication

- Interactive operation by means of LED display in the control box door
- Weight-controlled fill level indicator

● WEB HMI

- Alarm-related help texts with photos, videos and comment function
- Intuitive design
- Operation like a smartphone
- 15.6" multi touch screen
- Full HD display
- Comprehensive management of recipes and orders
- FDA-compliant user administration
- Logbook (optional)
- Web-based system

● Large control box

- High flexibility due to machine control S7-1500
- Integrated pneumatic control

● Stainless steel/acid protection coating

- Stainless steel design elements at the control box with high-quality acid protection coating

● Filling modes

- Below-surface, for products which produce foam during filling
- Below-bunghole, for uncritical products
- Above-surface, for uncritical products that are filled in open head containers
- With-surface, for high-viscosity products

● Different containers

On spot equipment: pivoting pallet filling system



Original Price
FCA Bad Oldesloe
EUR 114.230

Special Offer
FCA Bad Oldesloe

EUR 91.000

VERSION

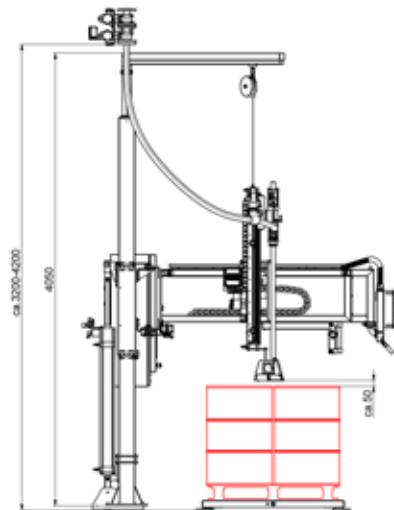
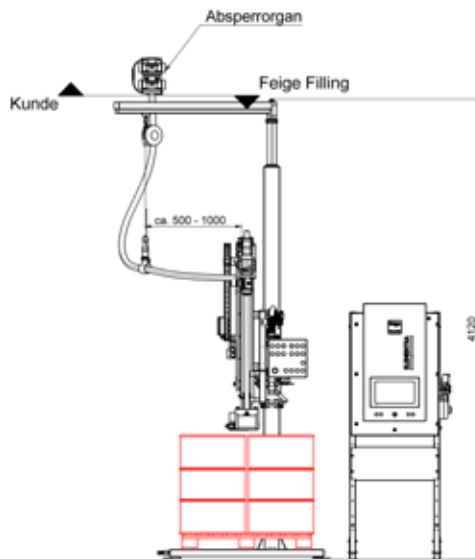

Configuration example
(Specifications in mm)

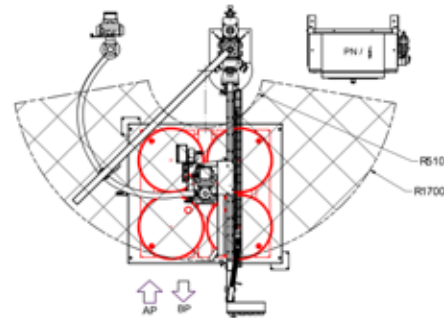
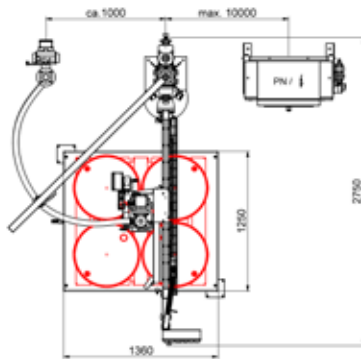

TECHNICAL DATA

	Degree of protection	IP55
Power supply and Performance data		230V or 3 ~ 400V, 50Hz
	Basic machine	0.5 kVA
	Electric lifting unit	0.75 kVA
Air pressure:		5 bar dynamic
Air consumption	Pneumatic lifting unit	40 standard litres/drum for below-surface filling
		30 standard litres/drum for below-bunghole filling
	Electric lifting unit	2 standard litres/drum for below- and with-surface filling
		2 standard litres/drum for below-bunghole filling
		2 standard litres/drum for above-surface filling
Ambient temperature		+5 to + 35°C, optional 0 to 55°C with heating and air conditioning unit
Product temperature		0 to 130°C
Nominal output		50 to 60 drum/h depending on product flow
Weighing ranges approved for verification		10 to 300 kg - increment 0.1 kg, to 1200 kg/1500 kg - increment 0.5 kg
		40 to 600 kg - increment 0.2 kg, to 1500 kg - increment 0.5 kg
		100 to 1500 kg - increment 0.5 kg, to 2000 kg - increment 1.0 kg
Weight		Approx. 500 kg, according to version
Product connection		Feige square flange, wide range of product hose selection
External control	Dry contacts	2 (coarse/fine)
	Analogue signal	4-20mA (for product pump or pilot valve)